

MELUN HIGH QUALITY TOUCHLESS COMMERCIAL SOAP DISPENSER SPECS

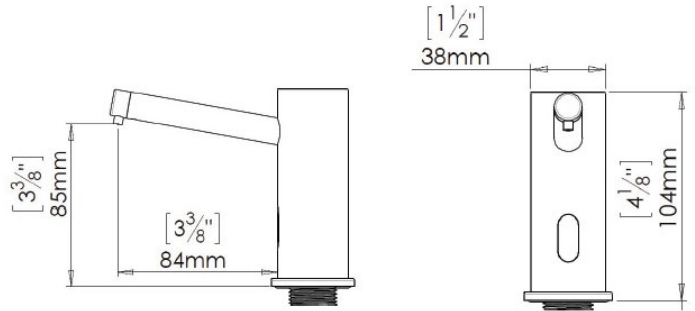

Size:



Specifications

- INSTALLATION: LAVATORY MOUNTED
- POWER SOURCE: 12 V TRANSFORMER
- DEFAULT SOAP DOSAGE: 1.4 CC
- SOAP VISCOSITY: 100-3800 CPS
- USAGE: COMMERCIAL RESIDENTIAL
- INLET/OUTLET DIAMETER: G-1/2
- ACTIVATION: INFRARED SENSOR
- SENSOR RANGE: SELF-ADJUSTING
- ACTIVATION TIME: < 1 SECOND

